

AI-708M MULTI-CHANNEL INDICATOR

Operation Instruction

Ver. 7.0

(Suitable for measure and alarm of temperature, pressure, flow, level, humidity etc.)

一、 General

AI-708M is designed with modular and intelligent principle. It has powerful program function on input signals and can be connected to different sensors such as thermocouple、 RTD、 voltage and current with different input module installed. Functions like digital calibration、 digital filter、 programmable input type and alarm output are also available. With ISO9001(version 2000) certification and compliance to EMC standard, it is reliable and has a good ability of anti-interference. Features:

With a high cost/performance by adopting universal YUGUANG V7.X version hardware module

The measurement accuracy is $\pm 0.2\%FS$, and to get this accuracy, functions like ice point compensation、 Cu50 copper resistance compensation and thermostat compensation are available for thermocouple input type.

With 6 programmable input channel, and, through combination of various input module, you can get a maximum of 6 input signals for thermocouple、 voltage、 current and 2-wire type RTD input or 3 input signals or 3-wire type RTD input.

Each input channel can be equipped with different input module and has digital filtering function. Scale and decimal point position can be set separately for input channel of linear voltage、 current and resistance signals. Shift calibration and resolution can be set separately for input channel of thermocouple and RTDS.

Input channel numbers for display is settable from 1 to 6. If 2 input channels are set, then 2 display window will show these 2 input signals at the same time.

It has the function of auto/manual pilot display, with 2 pilot speed selectable.

It has high、 low alarm function with alarm output channel settable for each input channel.

With 12 field parameters for you to customize your instrument.

In the application of analog signal access, each AI-708M can substitute 6 separate measuring instrument, and incorporated with the same communication protocol used by AI artificial intelligent controller, it can communicate with PC. This makes AI-708M be an ideal selection for you to construct your signal accessing system.. Newly added protocol command can make computer access 6 channels within 0.05 to 0.1 seconds.

二、 Model code symbol

Designed with modular principle, AI-708M can be equipped with 6 modules on 6 sockets, among which M1、 M2 and M3 can be equipped with various input modules, each of which has 1or 2 analog input channels; AL1、 AL2 and AL3 can be equipped with relay output module, each of which has 1 or 2 alarm output channels; COMM can only be equipped with RS485 interface for communication with computer; and M3 can be equipped with not only analog input module but also relay output modules.

AI-708M A — J1 J2 J5 L5 L5 S
1 2 3 4 5 6 7 8

The above code symbols a AI-708M instrument with: front panel dimension 96×96mm, 2 thermocouple input, 2 2-wire RTD input, 2 current input, 4 alarm relay output, and 1 RS485 communication interface. The explanation for each code is below:

1.Shows the basal function of instrument

AI-708M multi-channel pilot indicator.

2. Front panel type, the depth of the instrument is about 13.5mm(foreside)+100mm(rearward)

A front panel 96×96mm, cutout 92×92mm.

B front panel 160×80mm(width × height), horizontal, cut out 152×76mm

C front panel 80×160mm(width × height), vertical, cut out 76×152mm

D3 with modular housing, can be installed on DIN rail.

E front panel 48×96mm(width × height), cut out 45×92mm.

F front panel 96×48mm(width × height), cut out 92×45mm

3—8. symbols the module type installed on sockets (M1、 M2、 M3、 AL1、 AL2、 COMM):

N or no symbol no module installed

J0 input module for 1 thermocouple plus 1 2-wire RTD, or for 1 3-wire RTD input

J1 input module for 2 thermocouple or mV input (less than 500mV)

J2 input module for 2 2-wire RTD input

J3 2 channel voltage input module, 0-1V、 0-2.5V、 0-5V、 0-10V、 1-5V etc.

J4 2 channel current input module, 0-10mA、 4-20mA、 0-20mA

J5 2 channel input module for 2-wire transmitter, 24VDC power supply incorporated in the input module.

L2 1 channel relay contact (NO+NC) output module (capacity: 30VDC/1A, 264VAC/1A)

L5 2 channel relay normal open contact output module (capacity: 30VDC/1A, 264VAC/1A)

W1 1 channel no contact output module (“never burn out” technology, able to stand 0.3A continuous current or 1A transient current)

G 1 channel SSR voltage output module (DC 12V/30mA)

G5 2 channel SSR voltage output module (DC 12V/30mA)

- S optical-electric isolated RS485 communication interface
- S4 optical-electric isolated RS485 communication interface with its own isolated power supply.
- V24 isolated 24V/50mA DC power supply for transmitter. Other spec. below 24V optional.

三、 Technical specification

Input :

thermocouple and linear mV voltage : K、 S、 E、 J、 T、 B、 N、 0-20mV、 0-50mV、 0-100mV、 0-200mV、 0-50mV

RTDs : PT100、 Cu50、 0-80Ohm、 0-400Ohm

Linear voltage : 0-1V、 0-2.5V、 0-5V、 1-5V、 0-10V etc.

Linear current : 0-10mA、 0-20mA、 4-20mA etc.

lead wire resistance for RTD input

2-wire type RTDs: 2 Ohm for Pt100 and 0-400Ohm RTD input , 1 Ohm for Cu50 and 0-200Ohm RTD input ;

3-wire type RTDs: 5 Ohm

Measurement range :

K(-50—+1300)、 S(-50—+1700)、 WRe526 (0-2300)、 T(-200—+350)

E(0—800)、 J(0—1000)、 B(0—1800)、 N(0—1300)

Pt100(-200—+600)、 Cu50(-50—+150)

Linear input : -1999—+9999 set by user

measurement accuracy : $\pm 0.2\%FS \pm 1\text{digit}$ or $\pm 0.3\%FS \pm 1\text{digit}$ (only for Cu50)

note : Accuracy is not guaranteed between 0 and 600 for type B thermocouple input.

sampling time : 1.5 seconds (if digital filter parameter is set as 0 or 1)

automatic pilot time interval : approx. 1.2s or 2s configurable

alarm function : high and low alarm , configurable separately for each channel

alarm output :

relay contact output (NO or NC) : 264VAC/1A or 30VDC/1A

no contact discrete output (NO or NC) : 264VAC/0.3A(transient current 1A)

supply voltage: 85-264VAC/50Hz

power consumption : 6W

ambient temperature : 0-50

front panel dimension : 96*96mm、 160*80mm、 48*96mm、 96*48mm selectable

cut out dimension : 92*92mm、 152*76mm、 76*152mm、 45*92mm、 92*45mm

四、 Instrument wiring

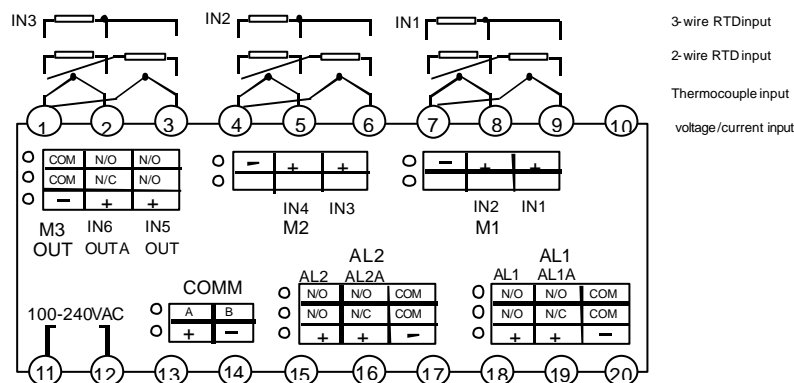

note: This diagram suits for horizontal instrument with front panel type B and F. For front panel type A, C and E, just rotate 90 degree clockwise.

五、 Front panel and operation

- OUT indicator Lamp
- AL1 indicator Lamp
- AL2 indicator Lamp
- AUX indicator Lamp(not used in local mode)
- setting key
- data shift key (also for cyclic display switching)
- data decrease key (also for changeover to show the preceding channel)
- data increase key (also for changeover to show the next channel)
- measurement channel number display
- measurement value display window

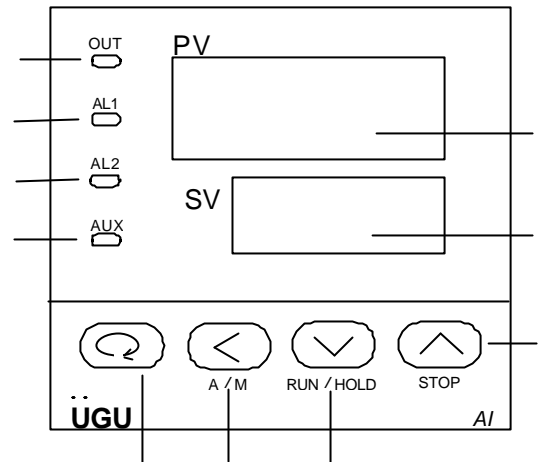

Basal operation description

1. Channel display changeover : press \downarrow key to decrease channel number, press \uparrow key to increase channel number, and press \leftarrow key to enter/exit cyclic display stalls.
2. Parameter Setting: Press and hold the key for about 2 seconds, until parameter is displayed . Press the key \leftarrow again, parameters such as high alarm HAL1, parameter lock LOC and so on will be displayed in turn. For the instrument already configured and in which parameters are Locked, only field parameters that operator needed can be displayed. Use \downarrow 、 \uparrow 、 \leftarrow keys to set parameter values. When parameter Lock is not set, press \leftarrow and \leftarrow keys simultaneously to exit from the status of parameter setting, press \leftarrow key to return and check the preceding one parameter.
3. The lower display window shows channel number. If high or low alarm occurs, the first digit from the left of lower display window will show "H" or "L", and flickers, and if over range occurs (for example, wire broken for thermocouple input), the upper display window will show high or low limit valve, and the lower display window flickers.
4. If only 2 input channel configured, then the upper and lower display window will show these 2 input value respectively. When over rang occurs, the corresponding display window will flickers.
5. Lead wire resistance compensation for 2-wire RTD input: a offset value (parameter "dil") need to be set to counteract lead wire resistance for 2-wire type RTD like Pt100 or Cu50. This offset value can be set automatically according to the following procedure: (1) Short connect 2 wiring terminals on the RTD sensor side. (2) Set parameter Loc=808, then press \leftarrow and hold for over 2 seconds, until the first digit from the right of the lower display window shows "A". (3) Wait until "A" disappear, and then remove the short wire, and set "Loc" as 0 or 1. Now, the instrument comes back to normal measurement display mode, and the setting of parameter "DIL" is finished.

六、 Parameter list

Symbol	Name	Setting range	Engineering unit	Remarks
H.AL1-6	High alarm	-1999—+9999	1 or 1 defined unit	1 defined unit is specified by parameter "DIL" and "DIH" for linear voltage/resistance input type
L.AL1-6	Low alarm	-1999—+9999	1 or 1 defined unit	
dF1-6	Dead band	0—2000	1 or 1 defined unit	
Sn1-6	Input type	0—3999		
dIL1-6	Low limit	-1999—+9999	1 defined unit	Shift calibration for temperature input
dIH1-6	High limit	-1999—+9999	1 defined unit	
ALP1-6	Alarm output	0—66		
Cn	Channel/speed	0—36		2-wire/3-wire selection for RTD
nonc	NO/NC selection	0—63		
Addr	Communication address	0—100		
BAud	Baud rate	0—576	× 100BIT/S	
Loc	Privilege	0—9999		
EP1-12	Field parameter	nonE—BAud		

1、 Alarm parameter H.AL1-6, L.AL1-6、 dF1-6

These parameters set instrument's alarm function.

H.AL High Limit absolute alarm. If the process value is greater than the value specified as "H.AL+dF", then the alarm is set, and the alarm will be cancelled if the process value is less than the value of "H.AL-dF".

L.AL Low Limit absolute alarm. If the process value is greater than the value specified as "L.AL-dF", then the alarm is set, and the alarm will be cancelled if the process value is less than the value of "L.AL-dF".

Limit value can be set to those parameters not used to avoid alarm function. Ex, the following configuration: H.AL1=9999, L.AL1=-1999 is set, even if the difference value is greater than 9999, H.AL1 and L.AL1 alarm will not be triggered.

Deadband parameter dF is set to permits protection of position control output from high switching frequencies caused by process input fluctuation.

For example: dF parameter can affect upper absolute alarm as the following, provided upper alarm parameter "H.AL1" is set as 800 , dF1 parameter is set as 2.0 .

(1) Instrument is in normal status at the beginning, when process value is greater than 802 (H.AL1+dF1), the upper absolute alarm can be triggered.

(2) Instrument is in upper alarm status at the beginning, when process value is less than 798 (H.AL1-dF1), then alarm can be cleared.

2、 Input specification parameter Sn1-6

Sn is a multi-parameter, the four number have different meanings. The primal and secondary number count from right (declared as Sn-12) means input specification. The third number count from right (declared as Sn-3) means input specification. The fourth number count from right (declared as Sn-4) means decimal point setting.

AI-708M series instrument is available with varied input function such as thermocouple, RTD, Voltage input and Current input after equip with Module J0,J1,J2,J3,J4 and so on. The following table shows input specification corresponding to the set value of parameter Sn-12.

Sn-12	Input spec.	Sn-12	Input spec.
0	K (-50—+1300)	1	S(-50—+1700)
2	WRe5-WRe26 (0—+2300)	3	T (-200—+350)
4	E (0—1000)	5	J (0—1000)
6	B (0—1800)	7	N (0—1300)
8-17	Spare	18	BA2/JPT100 (-200—+600)
19	G/Cu53 (-50—+150)	20	Cu50 (-50—+150)
21	Pt100 (-200—+600)	22—25	Spare for special RTD
26	0-80 Resistance input	27	0-400 Resistance input
28	0—20mV (J1)	29	0-50mV (J1) 、 0-2.5V (J3) 、 0-10mA (J4)
30	0-100mV、 0-5V (J3) 、 0-20mA (J4)	31	20-100mV、 1-5V (J3) 、 4-20mA (J4)
32	Spare	33	0-1V (J1) 、 0-50V (J3) Voltage input

Input digital filter parameter “Sn-3”

There is one intermediate-value filter system and one second order integral digital filter system in AI-708M series instrument, among which intermediate value filter takes intermediate value among three continuous values, and second order digital filter has the same effect as resistance-capacity integral filter. If measurement input fluctuates due to noise, then digital filter can be used to smooth the input. Parameter “Sn-3” may be configured in the range of 0 to 9, among which, 0 means no filter, 1 means intermediate-value filter and 2—9 means that intermediate-value filter and second order integral filter can be selected simultaneously.

The multiples of second integral filter is the square parameter “Sn-3”, and can be up to hundreds times. When a large value is set, the measurement input is stabilized but the responsibility at the time is deteriorated. Generally if great interference exist, then you can increase parameter “Sn-3” gradually to make momentary fluctuation of measurement input less than 2 to 5 values. If the instrument is being tested at laboratory, then parameter “Sn-3” should be set to 0 or 1 to short the time responsibility.

Decimal point setting parameter Sn-4

(1) In case of linear input, parameter DIP is used to define decimal point place according to users' habit.

Sn-4=0, display pattern is 0000, decimal point not displayed.

Sn-4=1, display pattern is 000.0, decimal point is at ten's place

Sn-4=2, display pattern is 00.00, decimal point is at hundred's place

Sn-4=3, display pattern is 0.000, decimal point is at thousand's place

Adjustment of this parameter affects display only, and gives no effect on measurement input accuracy and control precision.

(2) In case of thermocouple or RTD input, DIP is used to define temperature display resolution.

Sn-4=0, temperature display resolution is 1

Sn-4=1, temperature display resolution is 0.1

Adjustment of this parameter only affects the display, and gives no effect on control or retransmission output because the internal temperature measurement resolution is fixed at 0.1 , then temperature will be displayed at the resolution of 0.1 for input below 1000 and 1 for input over 1000 .

3、dIL1-6 and dIH1-6: Scale definition parameter for linear input / retransmission output

(1) Linear input includes signals of various specifications such as mV, 5V, 1-5V, 0-10mA and 4-20mA, display range of which is from -1999+9999 (decimal point can be defined by " Sn-4"). Parameter "dIH1-6" and "dIL1-6" are used to define the display span for linear input, and to set the engineering unit for measurement.

For example, a pressure transmitter is used to convert pressure signal (temperature, flow and humidity signals also possible) to stand 1-5V input. Among which, 1V corresponding to pressure 0 and 5V corresponding to pressure 1MPa, and the display resolution of 0.001MPa is expected. Each parameter can be set as the following:

Sn1 = 3133 (Select 1-5V DC Voltage input, Set Input digital filter parameter equal 1,Set decimal point, and the display pattern is "0.000")

dIL1 = 0.000 (Define the pressure display value corresponding to low input limit 1V)

dIH1 = 1.000 (Define the pressure display value corresponding to high input limit 5V)

(2) In case of thermocouple or 2-wire RTD input: Parameter dIL1-6 is used to make input shift to compensate the error produced by sensor or input signal itself. For thermocouple input, parameter dIL1-6 is used to correct reference junction compensation error. For 2-wire RTD input, parameter dIL1-6 is used to correct the wire resistance error.

The instrument itself will not produce error after a long time used, because the technology of digital calibration is used in the instrument to substitute potentiometer of bad stability, and the function of automatic zero modulation will guarantee no zero drift produced in the instrument.

4、Alarm output definition parameter “ ALP1-6”

The primal and the secondary number of ALP count from right (declared as ALP-1and ALP-2)means the alarm output channel of all alarm type of “H.AL1-6” and “L.AL1-6”. “ALP-1” and “ALP-2”may be configured in the range of 1 to 6, and used to define which alarm type of “H.AL1-6”, “L.AL1-6” is output to AL1,AL2,OUT,AL1A,AL2A,OUTA.

For example: ALP1=12,it means that AL1 is activated when upper alarm of channel 1 occurs and AL2 is activated when lower alarm of channel 1 occurs.

5、Function parameter “ C n”

Cn is a multi-parameter.The primal number count from right (declared as Cn-1) indicate thinput channel numbers for display. Cn-1 may be configured in the range of 1 to 6.If Cn-1 is set as 2, then 2 display window will show these 2 input signals at the same time.

The secondary number count from right (declared as Cn-2) may be configured in the range of 0 to 3. The meanings is as follow:

- 0、 highly pilot speed, 2-wire RTD input; 1、 slowly pilot speed, 2-wire RTD input
- 2、 highly pilot speed, 3-wire RTD input; 3、 slowly pilot speed, 3-wire RTD input

6、Alarm output normal open or normal close contact definition parameter “nonc”

Generally,the alarm output is normal open contact. Parameter “nonc” may be configured in the range of 0 to 63, and used to define alarm output normal open or normal close contact. Its function is determined by the following formula:

$$\text{Nonc}=\text{A} \times 1+\text{B} \times 2+\text{C} \times 4+\text{D} \times 8+\text{E} \times 16+\text{F} \times 32$$

A to F is used to choose AL1 to OUTA output normal open or normal close When A to F is set as 1,the corresponding output channel is normal close; when A to F is set as 0,the corresponding output channel is normal open.

7、Communicate with computer

When RS485 communication interface is installed as auxiliary function, parameter “Addr” and “Baud” is used to define the communication address and baud rate respectively for communication modules in the instrument. Communication baud rate can be configured in the ranged of 12 to 192bit/s,corresponding communication baud rate range of 1200--19200bit/s. And the address of the instrument can be configured in the range of 0—100. Instruments should have different address configured when they are installed in the same communication line.

The operation and the function of the instrument can be executed by using computer sustained with AIBUS communication protocol when RS485 communication module (with photoelectric isolation) is installed. Besides various application software developed by users, we also provide AIDCS for communication, it will run under the operating system of Windows95/98/NT. By using this software, AI series instrument with the number of 1-200 can be centralized monitored and controlled, while automatic record and print is available.

The data character format for communication interface is: 8 data bits, 1 stop bits, and no parity bit. CRC calibration is used for data check. AI series instruments can make up distributed control system together with computer. A demonstration software, which have detail description about distributed control system, is available for your ordering. When trouble occurs on computer, communication interface, and line, the instrument itself can still work as usual to maintain the control of process.

8、 Privilege for parameter set Loc

If parameter Loc is set to other values than 808, then only field parameters in the range of 0 to 12 and parameter Loc itself can be set. When parameter Loc is set to 808, user can set all parameters. Parameter Loc provides several operation privileges. When user has completed setting some important parameters such as input and output, parameter Loc can be set to other values than 808 in order to avoid field operators' accidental modification of some important operation parameters. See the following:

Loc=0 , modification of field parameters is allowed.

Loc=1 , allowed to display and view field parameters. But the modification of field parameters (except parameter Loc itself) is not allowed.

Loc=808, configuration of all parameters and setpoint is allowed.

If Loc is set to other values than the above mentioned, the result may be one of those above mentioned, and most of them are the same as when loc=1 is set.

9、 Field parameter definition: EP1—EP12

When configuration of the instrument is completed, most parameters will not need to be set by field operators. Furthermore, field operators may not understand many parameters, and may probably set parameters incorrectly by mistake and make the instrument unable to work.

Intelligent instruments are generally equipped with parameter lock function, but ordinary lock function always lock all parameters. Sometimes it is needed for field operators to modify or adjust some parameters such as H.AL and L.AL.

EP1—EP12 define 0—12 field parameters for operators' use in parameter table. Their parameter values are parameters except parameter EP itself like HAL1, LAL1, .etc, when Loc is set to 0, 1, 2, and so on, only parameters or setting values of program defined can be displayed, other parameters can not be displayed and modified. This function can speed up the parameter modification and prevent important parameters (like input parameters, such as Sn1-6) from modifying falsely.

Parameters from EP1 to EP12 can define 12 field parameters at most, if the number of field parameters is less than 12 (sometimes even none), it is necessary to define useful parameters from EP1 to EP12 in order, the first parameter which are not used is defined as none. For example, six parameters of H.AL1 to H.AL6 (all channels' upper alarm) are need to be modified by field operators, the parameter EP can be set as following:

EP1=H.AL1、 EP2=H.AL2、 EP3=H.AL3、 EP4=H.AL4、 EP5=H.AL5、 EP6=H.AL6、 EP7=nonE

Sometimes field parameters are not needed after we finish adjusting the instrument, we can set EP1 parameter as nonE.